

## View Port Installation:

SINGLE GLASS SHOWN  
INSULATED GLASS SIMILAR

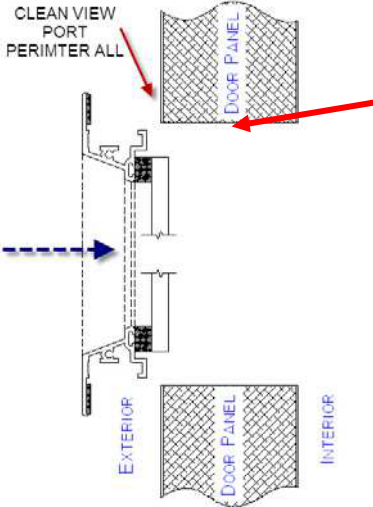

- ☑ Clean view port opening perimeter for installation.
- ☑ Determine the exterior side of the door. Obtain exterior view port assembly (*No clear or access attachment holes and contains glass*).
- ☑ Insert the exterior view port glass assembly into the hole.
- ☑ **\*\*NOTE\*\*** - When using insulated glass the view port assembly must be installed so the end of the breather tube is facing up or is at the top of the assembly.

**\*\*WHY\*\*** - Breather tubes are used to equalize pressure inside of an insulated unit. In the event that a breather tube is not orientated correctly, any condensation that may possibly exist will be cycled into the inside of an insulated unit.

- ☑ Center the view port in the opening allowing for equal spacing.
- ☑ The exterior view port frame has a 1/16" PSA closed seal black adhesive tape that when pressed against the door panel will hold the assembly in place.
- ☑ Measure the view port frame in several places to make sure that the frame is square with the door frame
- ☑ Peel PSA tape backer and press view port to door skin.

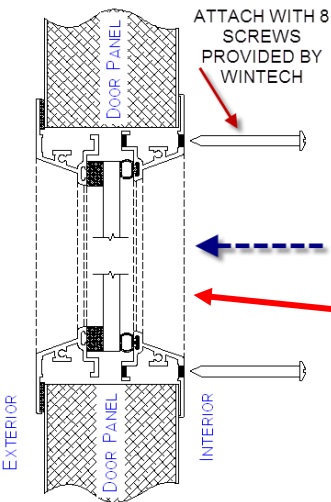
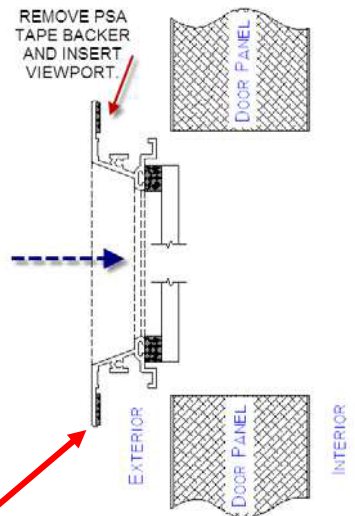

- ☑ Insert the inner view port frame assembly (*side with clear and access attachment holes and no glass*) to the exterior assembly making sure to line up the screw with the starter holes.
- ☑ Insert all 8 screws loosely. - ***Do Not completely tighten the screw at this time.***
- ☑ Check one more time to make sure the view port is square with the door frame. - ***\*Now tighten all screws in accordance to sequence on next page (Figure 1).***

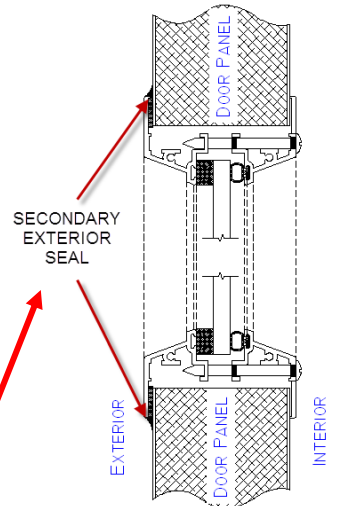

- ☑ Clean the view port frame and door panel with denatured alcohol or window cleaner.
- ☑ In the event that door skin or view port is not sealed completely, apply secondary exterior seal around view port.

EXTERIOR

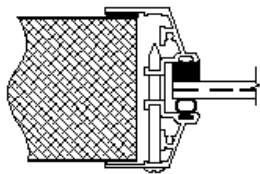

STANDARD

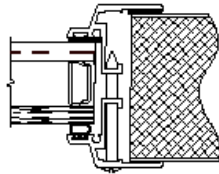

THERMAL

INTERIOR

### Attachment Sequence

\*WinTech uses, but limited to, a typical Makita Model BDF452 adjustable screw gun. WinTech uses a clutch setting of 14 to get the screw to bite in the access hole. A clutch setting of 14 is not meant for full screw penetration, but only for the bite into the access hole. There is no design torque established due to plus or minus tolerances in foam, skins, and other substrates that the viewport captures. Best application is that the viewport screws are tightened enough to compress the tape and or foam on the outside leg, but not too tight to dimple or bend the interior skins.

Upon getting the screws to bite into the exterior view port frame, tightening of screws needs to cross tightened. This sequence is very similar to tightening the lug bolts on a tire and referenced in **Figure 1 (left)**. If a single clock wise or counter clockwise attachment is done, this wracks the viewport against the glass. This wracking will cause tension, misalignment, and most likely breakage of glass. This tension can cause interior and/or exterior lites of glass to chip and break. This sequence is of the utmost importance to prevent glass breakage.

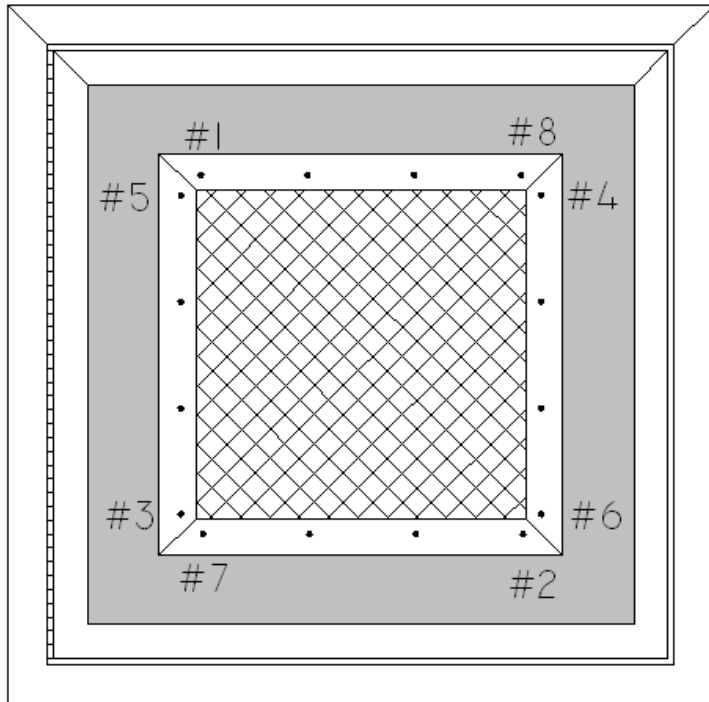

VIEWED FROM INTERIOR (FIGURE 1)

### Storage of Viewports

WinTech's viewport is designed to capture itself on the outside and inside skins of the door. It is a compression design and attaches to itself so there are no needs for structural support around the opening of the view port. Due to the final capture of the view port being the design principal, storage of view ports in a vertical manner can cause glass to distort or slide if not stored properly. It is recommended that Thermal or Insulated glass be stored in a horizontal position and not stacked higher than 40" tall. It is preferred and recommended that these units be stored in a cool, dry, humidity neutral environment to prevent distortion, glass drop, and or seal failure.

